

AIRMAN®

🇯🇵 JAPANESE QUALITY SINCE 1938

Mini -Excavator

Compliant with the EU stage V exhaust emission regulations

AX10U-7

1,110kg **0.022m³**

Operating weight

Bucket Capacity

Our Airman AX10U-7 Zero-tail swing mini-excavator, equipped with a powerful three cylinder stage V engine offers improved serviceability and safety, in addition to basic operations including digging, loading and leveling.



Compact design

- The AX10u-7 is designed to offer excellent productivity in confined spaces. It is the perfect machine to be used for projects such as housing foundations, indoor renovations, utilities and landscaping as the machine has a short-tail swing radius of 825 mm combined with the undercarriage with a minimum width of 780 mm that can be extended to 1000 mm for more stability.

Safety

- Use the lock lever to lock the levers for boom, swing and travel operation, thereby preventing improper operation.
- The machine utilizes a mechanism for starting the engine in neutral with the lock lever in the locked position.

Serviceability

- Front hoses are stored in the arm to protect them from damage. Articulated hose is used to make it easy to replace if it is damaged.
- A fully openable engine cover has been utilized.

Smooth Operation

- The hydraulic pilot control servo levers ensure accurate, smooth and precise operation.

Adjustable undercarriage width

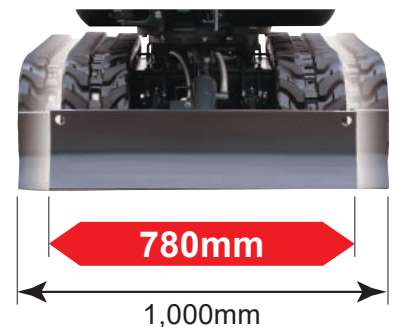

HOKUETSU INDUSTRIES EUROPE B.V.

Dimensions

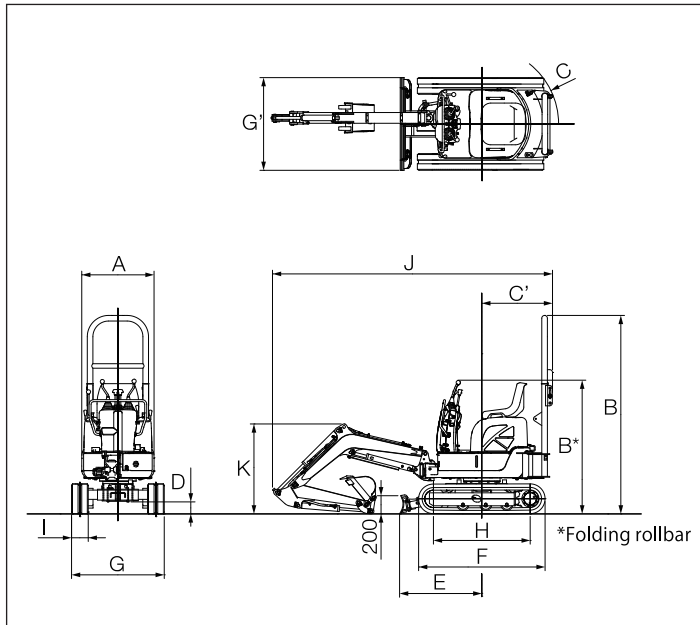

Specifications

Item	Model	AX10U-7
• Summary Specification		
Type of shoe		rubber
Operating weight	kg	1,110
Bucket capacity	m ³	0.022
Bucket width with sidecutter	mm	370
• Diesel Engine		
Model		Yanmar 3TNV70
Type		water cooling 4-cycle 3-cylinder swirl chamber type
Piston displacement	L	0.854
Rated output	kW/min ⁻¹	9.5 / 2,100 (12.9PS / 2,100rpm)
• Hydraulic Devices		
Main pumps (Max. oil flow)	L/min	gear type (10.6) ×2
Pilot pumps (Max. oil flow)	L/min	gear type (5.3) ×1
Main relief set pressure	MPa	17.7 (180kgf/cm ²)
Swing motor		High torque orbit motor
Travel motor		High-torque, 2-speed axial piston motor through planetary reduction gear
• Max. Digging Force		
Bucket	kN	11.8 (1,200kgf)
Arm	kN	6.0 (610kgf)
• Speed (2 speed system)		
Travel speed (high / low)	km/h	4.0 / 2.0
Swing speed	min ⁻¹	8.5
Gradeability degree	°	30 (58%)
• Others		
Ground pressure	kPa	24 (0.25kgf/cm ²)
Fuel tank	L	16.0
Hydraulic tank (Hydraulic system)	L	12 (18)
Engine oil	L	2.8

Working Range

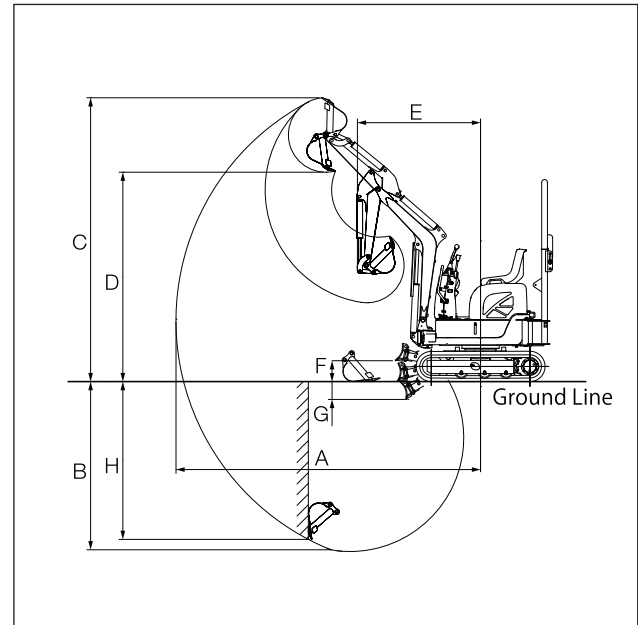

Dimensions

Item	Model	AX10U-7
A : Overall width	mm	780
B : Overall height (Folding roll bar)	mm	2,150 (1,450)
C : Rear-end swing radius	mm	825
C' : Rear-end swing length (with roll bar)	mm	760
D : Min. ground clearance	mm	130
E : Horizontal distance of blade installation	mm	885
F : Undercarriage length	mm	1,360
G : Undercarriage width: Extended / Retracted	mm	1,000 / 760
G' : Blade width: Extended / Retracted	mm	1,000 / 780
H : Distance between tumbler	mm	1,040
I : Track shoe width	mm	180
J : Max. transport length (Folding roll bar)	mm	3,020 (3,090)
K : Overall height of boom	mm	970

Working Ranges

Item	Model	AX10U-7
A : Max. digging reach	mm	3,220
B : Max. digging depth	mm	1,780
C : Max. cutting height	mm	3,010
D : Max. dumping height	mm	2,220
E : Min. swing radius (At max. boom swing)	mm	1,310 (1,100)
F : Blade bottom highest position above ground	mm	220
G : Blade bottom lowest position above ground	mm	190
H : Max. vertical wall	mm	1,670
I / I' : Offset distance (Max. boom-swing angle degrees)	mm	420 (55) / 535 (65)

- Thoroughly read the operation manual before using this machine to ensure correct and safe usage.
- Specifications and appearance are subject to change without notice.
- The photos used in this catalog were taken specifically for the catalog.
- When you leave the machine, be sure to follow the instructions in the operation manual.

HOKUETSU INDUSTRIES EUROPE B.V.
Aalsmeerderdijk 156, 1438 AX Oude Meer, Nederland
PHONE:31-20-6462636 FAX:31-20-6462191
e-mail:info@hokuestu.nl

SAFETY

- Operate safely in accordance with proper operation manual.
- To prevent trouble and accidents, perform daily and preventive maintenance checks without fail.



ISO9001 : JQA-0581
ISO14001 : JQA-EM4670